

STABILDRILL

INLINE FILTER SYSTEM

SD-700

BETTER
OVERALL
ECONOMICS

FASTEST FILTER
CHANGE ON THE
MARKET

MORE FLEXIBLE
AND EASIER TO
HANDLE

STREAMLINE MUD MANAGEMENT

THIS PROPRIETARY DON MASHBURN-DESIGNED SURFACE FILTER LETS YOU RAMP UP FLOW-THROUGH CAPACITY AND SPEED UP FILTER CHANGES.

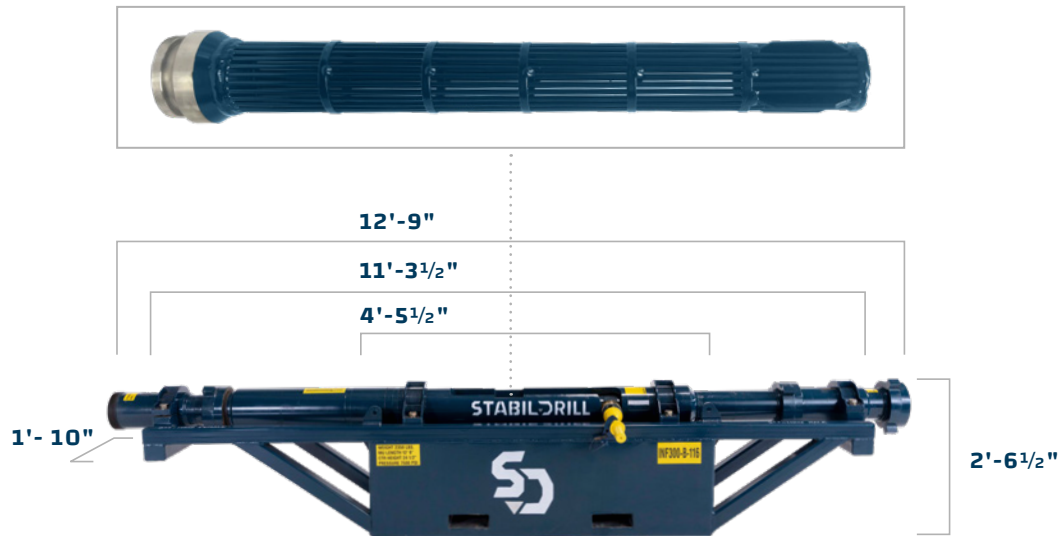

WANT EVEN MORE MWD PROTECTION?

DEPLOY BOTH THE SD-700 AND STABIL DRILL'S DOWNHOLE VORTEX FILTER SCREEN FOR THE ULTIMATE IN FILTRATION CONFIDENCE.

IMPROVE FLOW-THROUGH

THE FLOW-THROUGH LIMITATIONS OF TRADITIONAL SURFACE FILTERS SERVE AS A BOTTLENECK FOR OPERATIONS. THE INNOVATIVE SD-700 IS DESIGNED TO DELIVER UP TO 20% MORE FLOW-THROUGH TO HELP YOUR TEAM EXECUTE THE DRILL PLAN WITH STRENGTH AND INTEGRITY.

CHANGE FILTERS FAST

SLASH CHANGE-OUT TIME FROM 30-45 MINUTES TO LESS THAN A MINUTE, MINIMIZING NPT AND MAINTENANCE COSTS. THE SD-700'S BOLT ACTION DESIGN LETS YOU SIMPLY UNLOCK, SLIDE AND SWAP FILTERS—THEN YOU'RE READY TO GO.

STREAMLINE FIELD OPERATIONS

THOUGHTFULLY DESIGNED WITH CONVENIENTLY PLACED PADEYES, FORKLIFT POCKETS AND AN OPTIONAL SHORTER SKID DESIGN, THE SD-700 IS MADE FOR FAST HOOKUP AND EASY USE. ALSO PROMOTES REDUCED SETUP TIME FOR LESS OVERALL NPT.

KEEP EVERYONE SAFE

REDUCE SURFACE FILTRATION RISK WITH SAFER CHANGE-OUT: NO DROP RISKS OR HAMMER UNIONS THAT REQUIRE SLEDGEHAMMER WORK. THE UNIT ALSO FEATURES A SPILL CONTAINMENT TANK TO REDUCE SLIP AND FALL RISK. †

TECHNICAL SPECIFICATIONS	
WORKING PRESSURE	7500 MAX PSI
MAKE UP LENGTH	12'-9"
CENTER CONNECTION — STANDARD	24- ¹ / ₂ "
CENTER CONNECTION — SHORT	6- ¹ / ₂ "
UNIT WEIGHT	2350 LBS
END CONNECTIONS <small>Established at time of order, other connections available upon request.)</small>	5" 1502 or 5"1002
PICKUP/HANDLING POINTS	FORKLIFT POCKETS, PADEYES/SLINGS, OPEN TUBING FOR CHAIN/SLING LIFTING
FILTER SCREEN	24" TAPERED SLOT WIDTH: .100" @ TOP - .065" @ BOTTOM

